



A Division of The Toro Company

P.O.Box 787 Iron Mountain, MI 49801-0787

ISO 9001: 2008 REGISTERED

bossplow.com

TO: BOSS DEALERS

DATE: 11/17/15

SUBJECT: 2015+ Dodge Control Kits *****REVISED as of 12/2/15*****

The following is Service Bulletin **SV117 rev1** from BOSS Snowplow Technical Support. This Bulletin has been revised as of 12/2/15. The changes to this revision are:

- **Clarification on how to select the proper Control Kits for the 2015+ Dodge vehicles when using the BOSS Plow Selector (page 2).**
- **Changing the fuses on the RED/WHITE wires from 10 amp to 15 amp (page 4)**

Please make sure this bulletin is distributed to all employees who sell or service The BOSS Snowplow. We have distributed this service bulletin to all registered Distributors and Sub-distributors with dedicated fax lines or e-mail addresses.

Thank you,

BOSS Snowplow Technical Support

REGARDING: 2015+ Dodge Control Kits

Due to changes to the Body Control Module (BCM) on the 2015 and Newer Dodge 2500-5500, BOSS Products has developed a new 13-pin Vehicle Side Harness **MSC07287**. This harness is ONLY used on 2015 & Newer Dodge trucks (excludes 1500 & Power Wagon). This harness can be purchased separately, but will also be included in two new control kits below:

- **MSC07373 – 2015+ DODGE ONLY, CONTROL KIT RT3, V, SMARTTOUCH2**
- **STB07374 – 2015+ DODGE ONLY, CONTROL KIT RT3, STR SMARTTOUCH2**

These new Control Kits have been added to the drop down menu in the Plow Selector tool. The images below show the drop down menus for Straight and V plows. Be sure to choose the correct kit for the 2015+ Dodge trucks.

Plow Box	MSC15002 - PLOW BOX V RT3,SH2 8'2"/9'2",DXT,SL
Control Kit	MSC15100 - CONTROL KIT RT3 W/SH2 V SMARTTOUCH2,08+
Undercarriage	MSC15100 - CONTROL KIT RT3 W/SH2 V SMARTTOUCH2,08+
Additional Items Required	MSC15101 - CONTROL KIT RT3 W/SH2 V JOYSTICK,08+
	MSC17002 - NGE CONTROL KIT W/V SMARTTOUCH 2, 2013
	MSC17819 - NGE CONTROL KIT W/PISTOL GRIP, 2013
	MSC07373 - CONTROL KIT RT3 W/SH2,V ST2,DODGE 15+

Plow Box	STB15020 - PLOW BOX STR RT3,SH2 SUPER,08+
Control Kit	STB15103 - CONTROL KIT RT3 W/SH2 STR SMARTTOUCH2,08
Undercarriage	STB15103 - CONTROL KIT RT3 W/SH2 STR SMARTTOUCH2,08
Additional Items Required	STB15104 - CONTROL KIT RT3 W/SH2 STR JOYSTICK,08+
	STB17003 - NGE CONTROL KIT W/STB SMARTTOUCH 2,2013
	MSC17819 - NGE CONTROL KIT W/PISTOL GRIP, 2013
	STB07374 - CONTROL KIT RT3 W/SH2,STR ST2,DODGE 15+

NOTE:

- When installing the 2015+ Dodge harness, MSC07287, NO headlight adapters are required.
- NGE Control Kits are **NOT** compatible with any 2015 & Newer Dodge Vehicles at this time.

The 2015+ Dodge BCM no longer allows the OEM vehicle headlight circuits to supply power to an aftermarket headlight source (plow lights). As a solution to this, Dodge has supplied six upfitter wires located below the Power Distribution Center (PDC) see Figure 1. These upfitter wires only supply a signal to activate a secondary relay in our harness. These wires cannot be used to directly power any high current loads like plow lights. Testing these wires for voltage will not be possible, as the wire must detect the load from the relay before it signals.

When these upfitter wires are connected to the MSC07287 BOSS Harness, and the Truck/Plow rocker switch is placed in the Plow position, the BCM will deactivate vehicle HI and LOW beam and activate the upfitter wires.

Release tabs to move the PDC

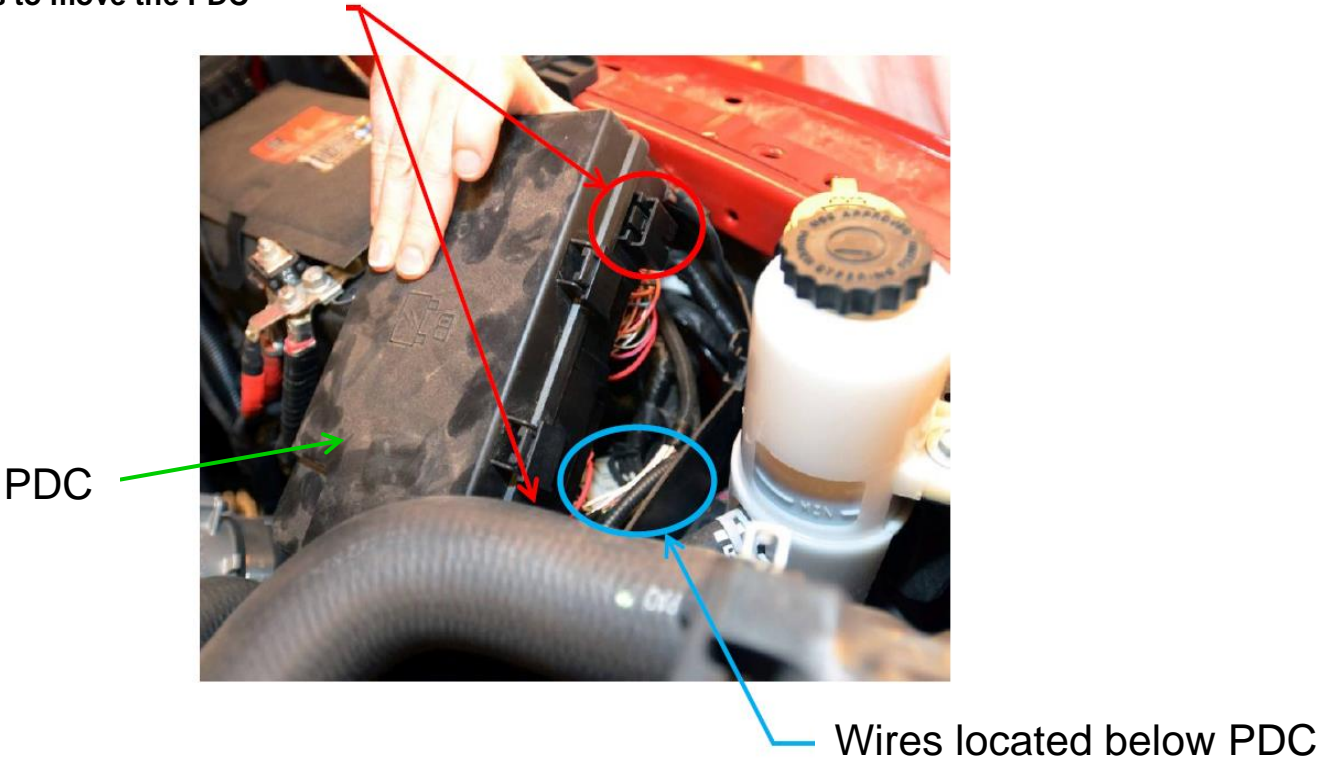

Early versions of the MSC07287 harness included 10 amp fuses on the RED/WHITE wires that connect to battery positive (+). In certain circumstances, the 10 amp fuses can fail causing a loss of power to the plow controller and loss of plow headlights. The solution to this is changing the 10 amp fuses to 15 amp fuses in all three of the RED/WHITE wires. Going forward, all MSC07287 harness shipping from BOSS will have 15 amp fuses on the RED/WHITE wires.

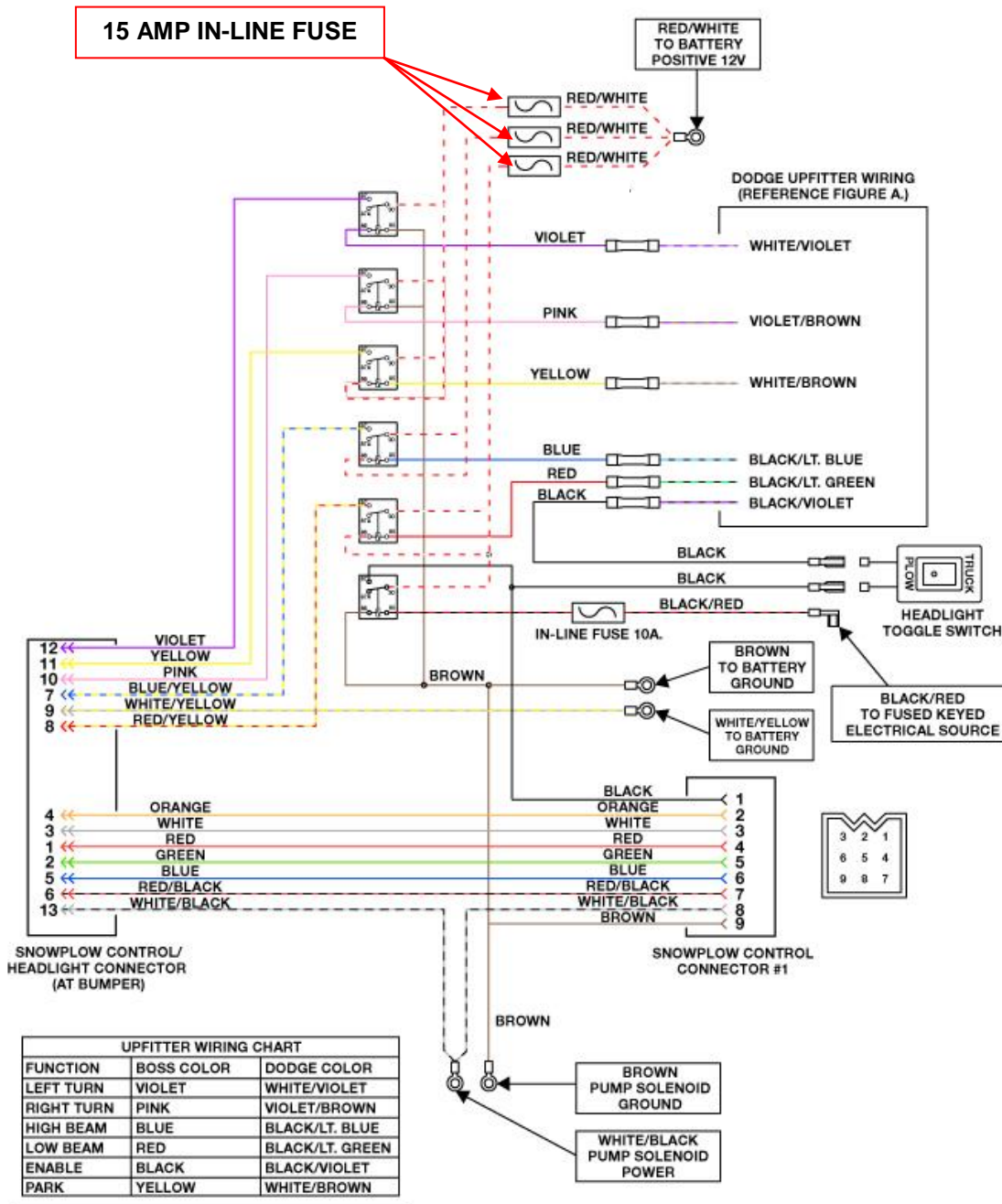

FIGURE A.

If you have any concerns or questions about this service bulletin please feel free to contact BOSS Technical Support at (800) 286-4155 option 2 or e-mail at techservice@bossplow.com