

Hydraulic Power Unit Fill Procedure

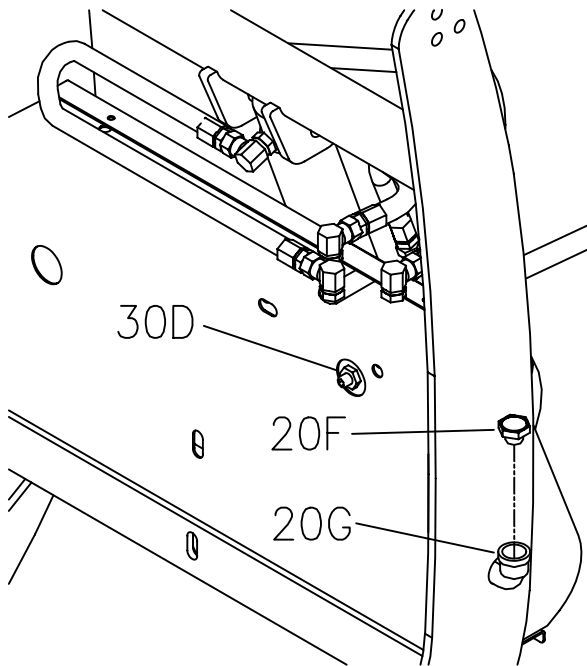

Figure 36. External Fill – Backside View G10124

Step 1 of the following fill procedure is intended for a new plow with an empty hydraulic system.

Initial Plow Position: Start with the plow un-attached from the vehicle and the lift cylinder completely collapsed. The light tower will be tilted forwarded.

1. Remove **HYD04810** Fill Cap (20F) from **HYD04809** Street Elbow (20G) and fill with Boss High Performance Hydraulic Fluid. Continue to fill Street Elbow (20G) until no more fluid will be accepted. (Approx. 2 quarts.)
2. Attach the plow to the vehicle.

Note: If your plow is equipped with SmartHitch 2™ you must hydraulically power the light tower up. Do not manually push the tower up. Failure to hydraulically power the light tower up will create an air pocket in the hydraulic system. Oil will spill out of your internal filler cap.

3. Raise the plow.

4. With the plow in the raised position, cycle through both angle functions several times.
5. Lower the plow to the ground.

Note: If your plow will not lower, Flow Control Valve (30D) is completely closed. Refer to Step 8 to adjust Flow Control Valve (30D).

6.

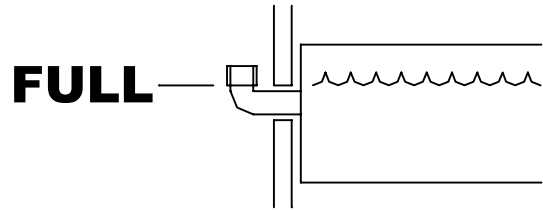

Figure 37. Oil Full Level

G00000

Plow Position to Check Oil: The plow should be attached to the truck, setting flat on the ground, with the blade in the straight position.

7. With the blade in the straight position and the plow lowered to the ground, check the fluid level. Fluid should be visible in the external fill port. If fluid is not visible, fill until visible. Your reservoir should now be properly filled.

Note: If your plow is equipped with SmartHitch 2™ you must hydraulically power the light tower down. Do not manually pull the light tower down. Failure to hydraulically power the light tower down will create an air pocket in the hydraulic system. Oil will spill out of your internal filler cap.

WARNING: When adjusting Flow Control Valve (30D) make sure all appendages are clear of the plow blade and observers are standing a safe distance away from the plow blade. The plow may drop if your controller is in the FLOAT position. Make sure your controller is in the OFF position before attempting to adjust the plow. Failure to follow this warning could result in bodily harm.

8. Adjust Flow Control Valve (30D) to obtain the speed desired for lowering the plow by loosening the jam nut, then adjusting the set screw. Counter-clockwise adjustment will increase the speed the plow descends. Retighten the jam nut when the desired speed is obtained.