

BOSS PRODUCTS
A Division of Northern Star Industries, Inc.
P.O. Box 787 Iron Mountain MI 49801-0787
www.bosspow.com

RT3 Tailgate Spreader Handle Installation Instructions TGS15610

PUSHING THE EDGE.

MSC15614

RT3 Spreader Handle Installation Procedure

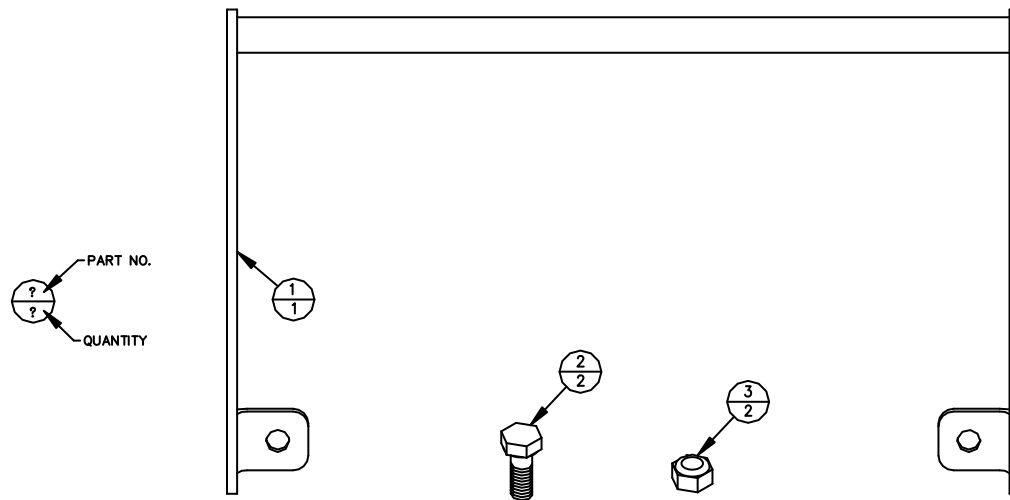

REF. NO.	DESCRIPTION	PART NO.	QTY.
1	HANDLE, SPREADERS WITH RT3	TGS15610	1
2	1/2"-13 X 1" GRADE 5 BOLT	HDW01781	2
3	1/2"-13 GRADE C OVAL TOP LOCK NUT	HDW05554	2

Figure 1. Handle Kit Components

G10610

1. Start by locating all necessary parts for handle installation as shown in Figure 1.
2. Examine front of Spreader Frame. If there are two 9/16" diameter holes, skip to Step 4, otherwise continue to Step 3.
3. Drill two 9/16" holes in front face of Spreader Frame as shown in Figure 2.

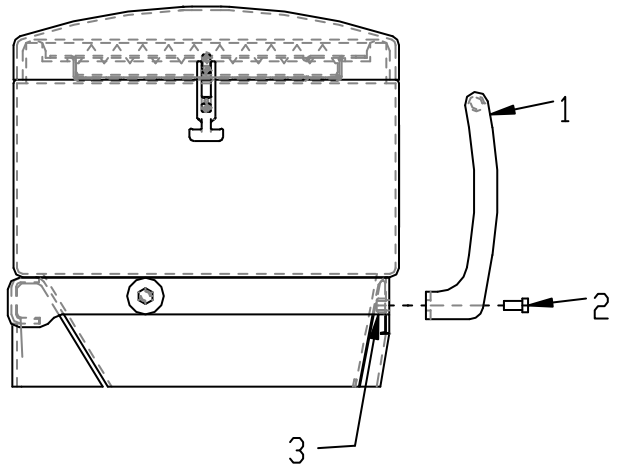

Figure 3. Handle Assembly

G10612

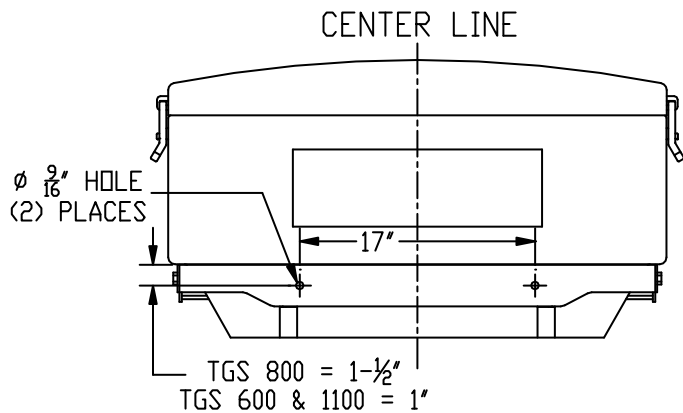

Figure 2. Hole Placement

G10611

4. Assemble Handle (1) to Spreader Frame using two 1/2"-13 X 1" Bolts (2) and two 1/2"-13 Grade C Oval Top Lock Nuts (3). See Figure 3.