

RT3 Undercarriage

for 2007-2010 Bobcat 2200/2300/3400 4x4, 2008 and After Case IH Scout/XL, 2007 and After Club Car XRT 1550, 2007 and After Husqvarna 4421/XL HUV, or 2008 and After New Holland Rustler 120/125 UTVs

Part No. LTA12680

Installation Instructions

⚠ WARNING

CALIFORNIA Proposition 65 Warning

This product contains a chemical or chemicals known to the State of California to cause cancer, birth defects, or reproductive harm.

Safety

- Always follow the vehicle manufacturer's recommendations relating to system installation.
- Due to the variety of equipment that you can install using the undercarriage, ensure that the gross-vehicle-weight rating (GVWR) is not exceeded at any time. You may need to weigh the vehicle and add ballast or limit the payload of the vehicle to compensate.

Installation

1. Park the machine on level ground, engage the parking brake, shut off the engine, and remove the key.
2. Remove and retain the 4 bolts securing the vehicle front bumper to the frame, and set the bumper aside.

Note: You may need to loosen or pull forward the front plastic parts in order to complete this installation.

3. Secure the plow skidplate and spacer plate to the vehicle frame using 4 bolts (M10) and 4 nuts (M10), and leave the fasteners finger-tight (Figure 1).

Note: Do not use the spacer plate if the vehicle has a front hitch receiver.

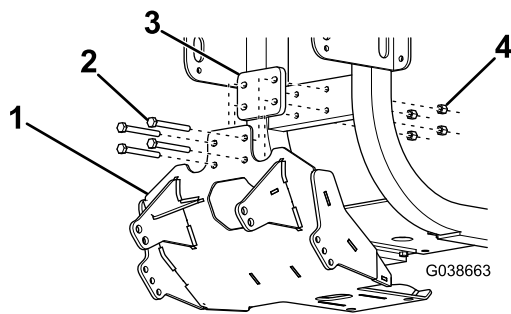

Figure 1

- | | |
|-------------------|-----------------|
| 1. Plow skidplate | 3. Spacer plate |
| 2. Bolt (M10) | 4. Nut (M10) |

4. Secure the back of the plow skid plate to the vehicle using 2 bolts (M12), 4 washers, 2 spacers, and 2 nuts (M12), and leave the fasteners finger-tight (Figure 2).

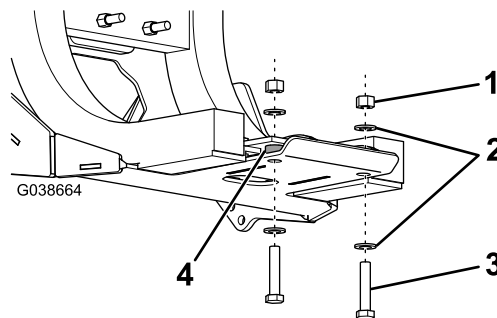

Figure 2

- | | |
|--------------|---------------|
| 1. Nut (M12) | 3. Bolt (M12) |
| 2. Washers | 4. Spacer |

5. Torque the M10 bolts to 48 N·m (36 ft-lb), and torque the M12 bolts to 124 N·m (92 ft-lb).
6. Mount the pushbeam to the plow skid plate using 4 bolts (1/2 inch), 4 nuts (1/2 inch), 6 bolts (3/8 inch), and 6 nuts (3/8 inch) as shown in Figure 3.

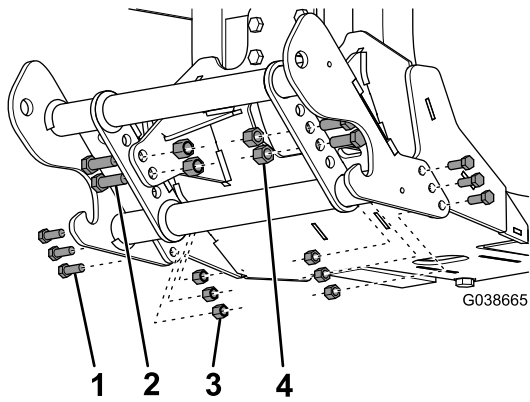

Figure 3

- | | |
|--------------------|-------------------|
| 1. Bolt (3/8 inch) | 3. Nut (3/8 inch) |
| 2. Bolt (1/2 inch) | 4. Nut (1/2 inch) |

-
7. Torque the 1/2-inch bolts to 76 N·m (56 ft-lb), and torque the 3/8-inch bolts to 31 N·m (23 ft-lb).
 8. Apply the BOSS decal to the top tube on the pushbeam ([Figure 3](#)).