

BOSS PRODUCTS
A Division of Northern Star Industries, Inc.
P.O. Box 787 Iron Mountain MI 49801-0787
www.bossplov.com

**2015 & NEWER
CHEVROLET ³/₄ TON
BUMPER TRIM
MOUNTING INSTRUCTIONS
(PART NO. MSC09279)**

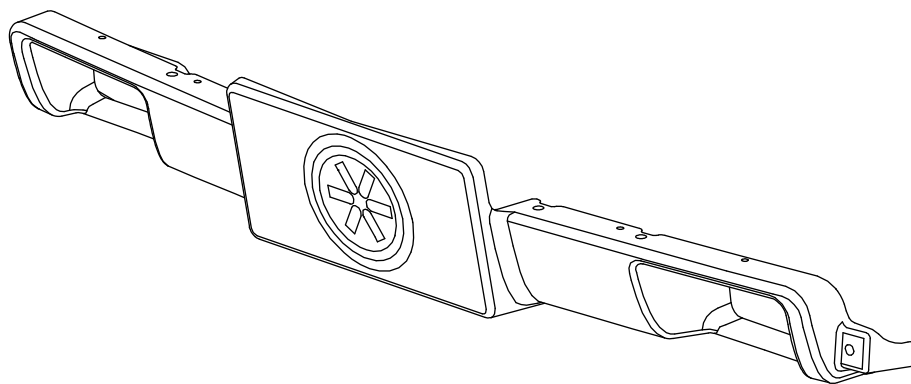

WARNING

Many newer trucks are now equipped with air bags. DO NOT under any circumstances disable, remove or relocate any sensors or other components related to the operation of the air bags.

Always follow the vehicle manufacturers' recommendations relating to snowplow installation. For recommended vehicle models refer to the BOSS Snowplow Application Chart and Selection Guide.

To comply with Federal Regulations and to assure a safe vehicle, the Front Gross Axle Weight Rating (FGAWR), Rear Gross Axle Weight Rating (RGAWR), and the Gross Vehicle Weight Rating (GAWR) must not be exceeded at any time.

Due to the variety of equipment that can be installed on this vehicle, it is necessary to verify that the Front Gross Axle Weight Rating (FGAWR), Rear Gross Axle Weight Rating (RGAWR), and the Gross Vehicle Weight Rating (GAWR) are not exceeded at any time. This may require weighing the vehicle and adding ballast as necessary. It may also limit payload capacity of the vehicle. It is the operator's responsibility to verify that these ratings are not exceeded.

2015 & NEWER CHEVROLET ¾ TON MOLDED BUMPER TRIM MOUNTING INSTRUCTIONS

1. Remove the grill to access the bumper mounting bolts.
2. Disconnect any electrical connectors that may prevent bumper removal. Remove the bumper and place face down on cardboard, shop towels, or a suitable surface that will not damage the front of the bumper.

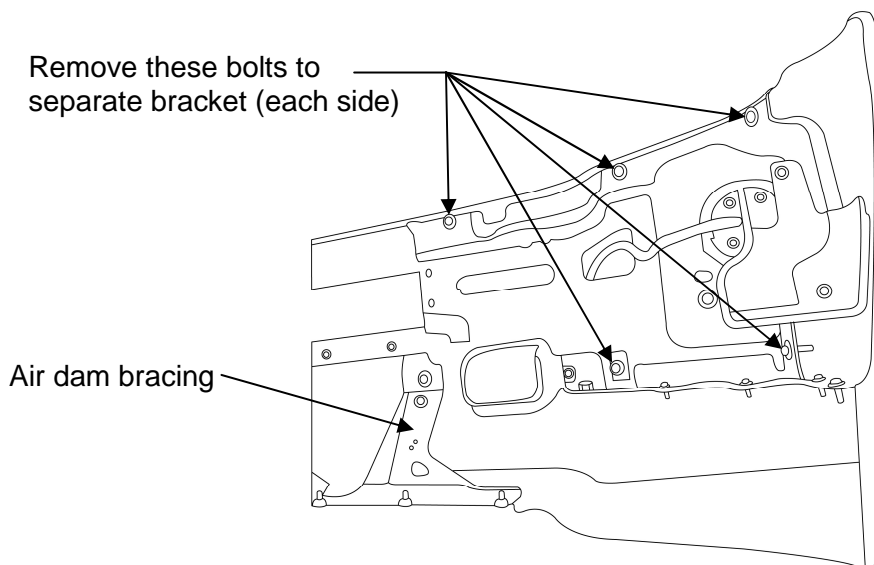

Figure 1

G10839

3. Remove the bolts holding the rear brackets to the bumper shell (see **Figure 1**); be careful to remove any sensors, lights, or wiring that may be fastened to the bumper shell.

4. Remove the air dam bracing and upper trim piece to expose the air dam mounting bolts, remove the air dam.
5. Remove j-nuts from the air dam and reinstall them on the replacement trim, insert the trim piece and reinstall the factory hardware. There will be extra hardware that needs to be saved and stored with the factory air dam. If necessary, install license plate on the replacement trim using the factory hardware or suitable screws.
6. Reinstall the rear brackets to the bumper shell; reconnect any sensors, lights, or wiring that was removed. Do not install the air dam bracing, retain it with the extra hardware in case of undercarriage removal.
7. Reinstall the bumper and grill. There should be adequate clearance between the trim and Push-Beam hook to allow proper connection to the plow.